

VOOL

VOOL Charger
Installation Manual

Safety Instructions	3-5
Product Description	6-7
In the Box	8
Installation Kit	9
Installation	10
Choose a Location	11
Electrical Requirements	12
Mounting Post Installation	13
Wall Installation	14
Installation	15-16
Step 1: Install the Charger Case	17
Step 2: Route Wiring Through Charger Case	18-20
Step 3: Connect the AC Power Supply Cable	21-22
Step 4: Install the Charge Controller	23
Step 5: Plug in the Ethernet Cable (Optional)	24
Step 6: Step 6: Plug in the Charge Controller Lid	25
Step 7: Snap on the Front Panel	26
Connect the VOOL Charger to the VOOL Network	27-29
Troubleshooting	30-32
Technical Data	33-34
Warranty Information	35
General Terms	36
Limits of Liability	37
Laws and Dispute Resolution	38

Safety Instructions

Please read these instructions before installing, operating, or maintaining the VOOl Charger.

- ⚠ For safety reasons, avoid installing or using the VOOl Charger near flammable, explosive, harsh, combustible materials chemicals, or vapors.
- ⚠ To ensure proper installation, an authorized installer must carry out all installations. Incorrect installation can damage the charger or the vehicle's battery.
- ⚠ The VOOl Charger should not be used by individuals with a lack of experience or knowledge without the supervision of a responsible party.
- ⚠ Turn off the power from the main switch before installing or configuring the VOOl Charger.
- ⚠ The VOOl Charger is intended solely for electric vehicles.
- ⚠ The VOOl Charger must be grounded via a permanent wiring system.
- ⚠ Use the VOOl Charger only within the specified operating parameters.
- ⚠ Avoid inserting any foreign items into the VOOl Charger to prevent damage.
- ⚠ For safety reasons, avoid direct liquid splash to the VOOl Charger and charge handle. Always put the charge handle back on the dock to minimize contact with moisture or contaminants.
- ⚠ Modifying the equipment or any part of the product is strictly prohibited.
- ⚠ For safety reasons, do not use the equipment if it appears to be damaged.
- ⚠ The VOOl Charger must be installed correctly to prevent damage to the charger and the battery of the vehicle.

- ⚠ The installations must comply with local regulations. Do not exceed power limitations.
- ⚠ To avoid potential damage, it is important to put the charging cable back onto the holder, so it cannot be stepped on, driven over, or tripped on.
- ⚠ To prevent overheating, unroll the charging cable completely before use.
- ⚠ Do not use cleaning solvents on VOOOL components. A clean cloth must be used to remove dirt and dust.
- ⚠ Do not use adapters for charging connectors.
- ⚠ Do not use cord extensions for charging cables.

The Product

Product Description

Congratulations on choosing the VOOL EV charger.

A product that not only provides a charging solution but also helps to contribute to a cleaner environment. Before using the charger, read all safety information. It is important to keep in mind that the installation works should only be carried out by an authorized installer who follows all the local country installation guidelines and regulations.

Load management regulates EV charging to prevent overloading your local electrical grid. It adjusts power use, reducing it during high-demand times and increasing it in off-peak periods. This benefits you with lower electricity bills and extends the life of your EV and charger. It also helps the environment by reducing carbon emissions and promotes grid stability.



1. Charger Installation Quick Guide
2. Programmable VOOO RFID tag
3. Screws, dowels and bolts for installation on wood, concrete wall or metal post
4. Grommets for all cable entries
5. Charger casing opening tool (also a handy bottle opener)
6. Charger case
7. Charge Controller
8. 6.5m cable with pre-installed cable stopper and green socket and Type-2 plug
9. Front panel with decorative plate

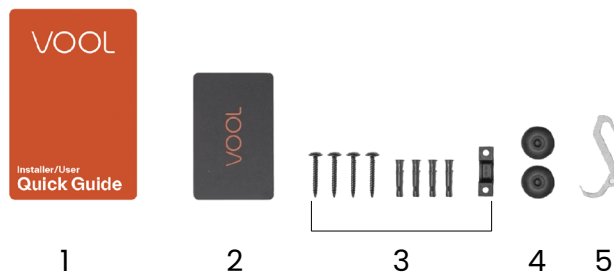

6



7



8



9

Tools required for full installation

- Pen
- Wire cutter
- Voltmeter or digital multimeter
- Flathead screwdriver (for the electrical sockets)
- T20 Torx driver (for the cable clamp)
- PH2 screwdriver (for mounting on concrete and wood)
- Size 3 Hex driver (for the mounting post)
- Ferrules (the diameter of the ferrule depends on the diameter of the power wiring and the construction)
- Level
- Power drill

Installation

Choose a Location

When choosing a location verify that the correct power supply, best possible WiFi, and space requirements are met.

The VOOL Charger must be installed in a location with sufficient space around it, allowing the charging cable to comfortably wrap around the unit and dock the charging handle without any difficulty.

The VOOL Charger should be installed in a place where you can easily charge the electric vehicle without putting strain on the cable. For example, the charger should be installed in a place where you can comfortably move around the vehicle.

The charger can be placed on the wall or the mounting post.

For best possible WiFi signal reception, avoid installing the VOOL Charger on opposite sides of physical barriers such as concrete, masonry, metal studs, or other obstacles that could hinder WiFi signal reception.



Electrical Requirements

- ⚠ Before starting any electrical installation remember that all local building codes, safety regulations, and equipment requirements must followed at all times.
- ⚠ The electrical work should be carried out by a qualified installation engineer.
- ⚠ Plan and design electrical works so that the load requirements, voltage, current, and desired functionality of the electrical system are taken into account.
- ⚠ Determine the maximum operating current.
- ⚠ Choose conductors that comply with local regulations.
- ⚠ Do not exceed power limitations.
- ⚠ Choose a cable that is suitable for the installation
- ⚠ The VOOO Charger must be grounded via permanent electrical installation.
- ⚠ Turn off the power supply to the area where the installation will take place and take all appropriate safety measures.
- ⚠ Gather all necessary equipment, including wires, connectors, fasteners, etc.
- ⚠ Test the electrical systems to ensure that they are functioning correctly and safely using appropriate testing equipment.

Minimum 2.5 mm² for 11 kW (16A)

Electrical conditions in the facility and cable lengths may require a higher cross-sectional area to meet the triggering conditions.

Minimum 6 mm² for 22 kW (32A)

Mounting Post Installation

The holes for the charger case have already been made in the post - no drilling necessary.

The mounting post can be bolted to a solid surface or rooted in the ground. Select where you would like to install the charger and choose a suitable location for the post. The post can be purchased with the VOOL Charger. It is possible to fasten the charger to posts from other manufacturers, but keep in mind that it must be capable of supporting the weight of the charger and accessories (4 kg).

For cable installation cut a hole into the cover panel and use the supplied grommet for the power supply cable. Optionally, use the smaller holes with smaller grommets for the Ethernet cable penetrations.

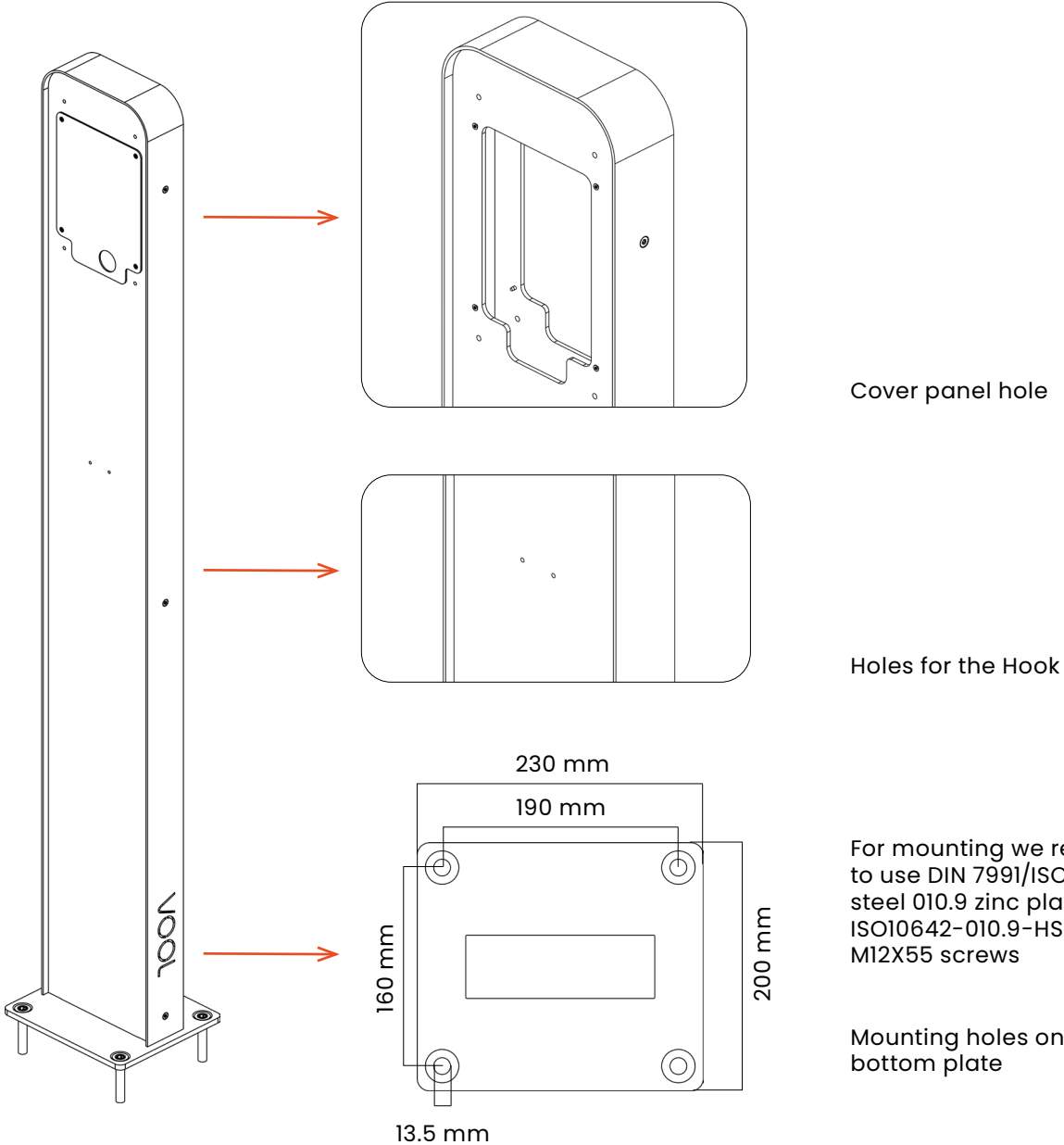

Wall Installation

Choose a suitable location to install the charger on the wall. The wall should be stable, flat, and suitable to support the weight of the charger.



Installation

1. Install the Charger Case
2. Route Wiring Through Charger Case
3. Connect the AC Power Supply Cable
4. Install the Charge Controller
5. Install the Ethernet Cable (Optional)
6. Install the Front Panel

 Before installation ensure that the power supply cable is disconnected.

Ensure a type A RCD is installed on the supply line of the VOOOL Charger (4 pole, 40A, 30mA for 22kW and 4 pole 25A, 30mA for 11 kW).

Make sure to use proper dimension circuit breakers.

For an 11 kW charger at least 16 (3 pole) circuit breaker with at least B-type characteristics and for a 22 kW at least 32A (3 pole) circuit breaker with at least B-type characteristics.

Step 1: Install the Charger Case

Step 1: Install the Charger Case

- 1.1 Position the charger casing against the wall and use it as a template to mark the hole locations if the wall needs to be drilled first.
- 1.2 Use a level to make sure that the casing is aligned evenly.
- 1.3 If needed - drill the mounting holes and insert the plugs for the mounting holes.

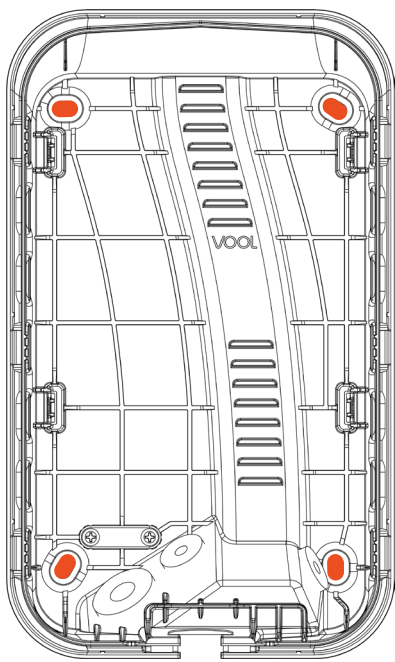

1.1

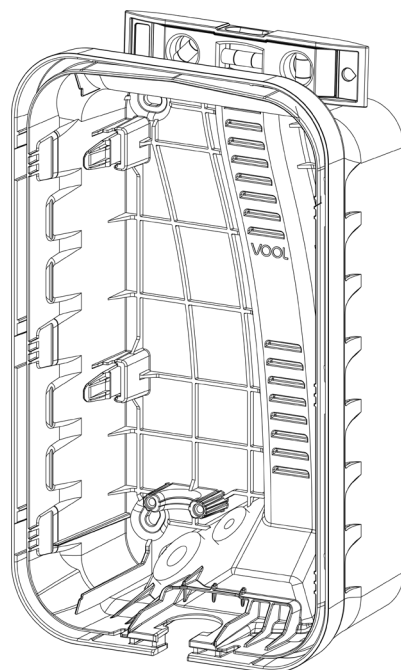

1.2

Step 2: Route Wiring Through Charger Case

Step 2: Route Wiring Through Charger Case

The cable can be inserted directly through the bottom, or through the top and routed behind the casing and inserted in the bottom (2.1). If the cable is connected from the top of the charger (2.2), cut or break away the top part of the casing as indicated (2.3). For top installation bend the cable to a hook with an inner diameter of approximately 60 mm while making sure not to damage the outer insulation of the cable if using hard tools such as pliers to hold the cable.

The cable can be inserted directly through the bottom, or through the top and routed behind the casing and inserted through the same bottom opening.

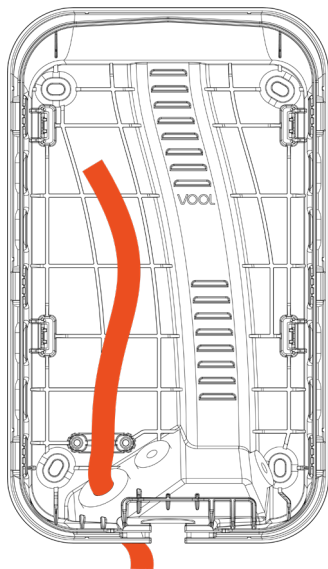

2.1 From the bottom

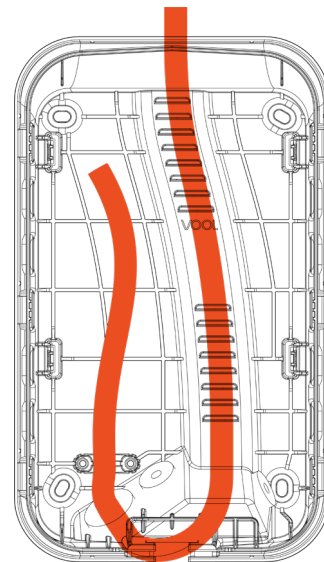

2.2 From the top

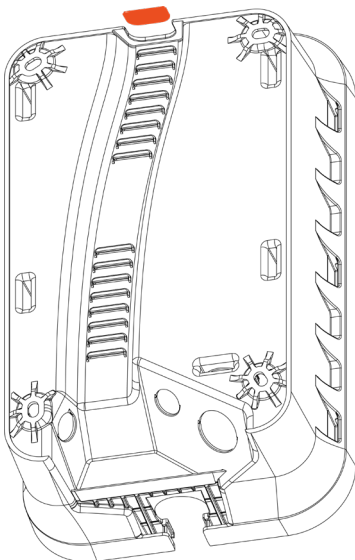

2.3 Breakaway

Step 2: Route Wiring Through Charger Case

Before inserting the cable into the charger case, strip the end of the outer insulation of the cable by 400 mm. If the cable is being routed through the top and inserted in the bottom, the wire should run in the dedicated tunnel on the back side of the charger casing. Ensure that there is a sufficient length of cable for installation, depending on the installation direction (top or bottom).

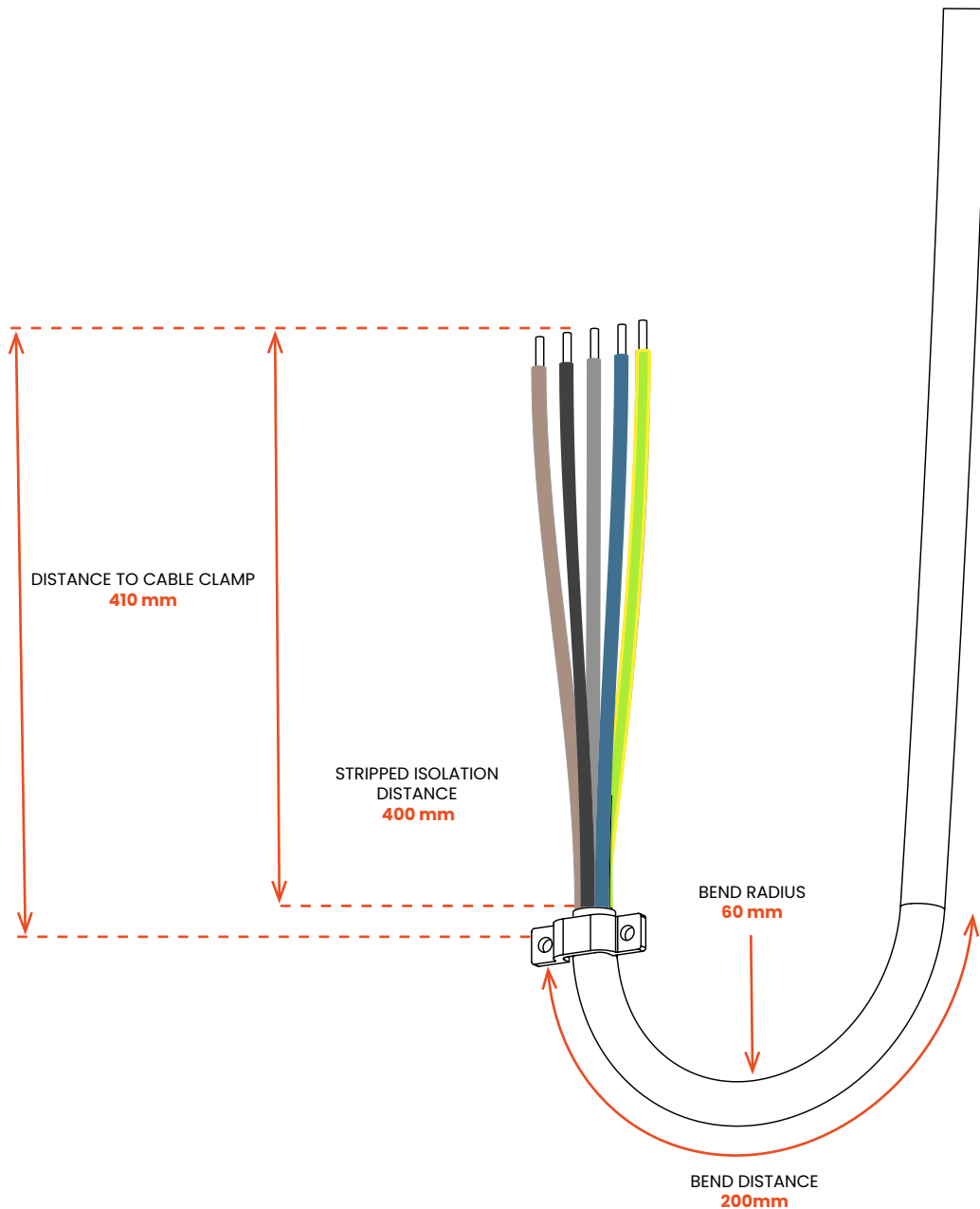

Step 2: Route Wiring Through Charger Case

- Cut a hole into the larger grommet that comes with the charger based on the cable size.
- Fix the grommet on the charger case.
- Insert the cable into the charger case through the grommet before fastening the charger case to the wall.
- Fix the charger case onto the wall.
- Use the cable stopper to fix the cable inside the case.
- Secure the cable with strain relief.
- Install 2 screws for strain relief.
- Pay attention to leave about 5-10mm of cable insulation above the cable stopper.

Step 3: Connect the AC Power Supply Cable

For the VOOl Charger you can use a single-phase or a three-phase AC power supply cable. The main differences between single-phase and three-phase AC power supply cable lie in the number of conductors, voltage levels, and power distribution methods. Three-phase power system can operate at higher voltage levels, the power is distributed in a balanced manner across the three conductors, and the current power supply is more constant and smoother. Three-phase power is used when there is higher electricity demand.

Connect the AC Input Cable - Single-Phase Power

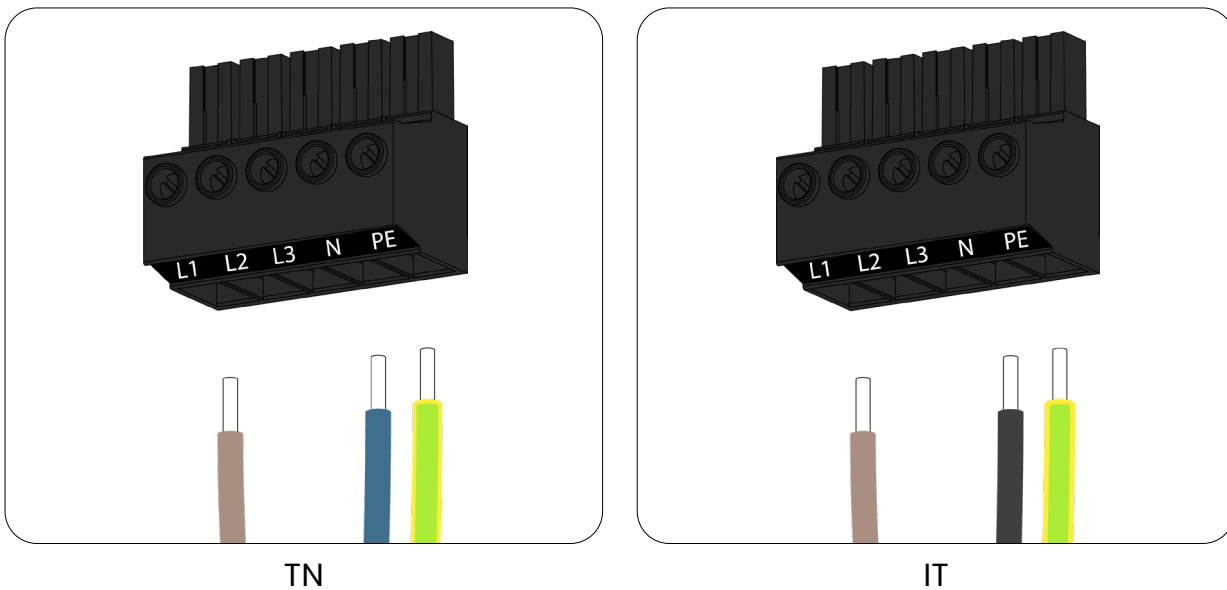

- Unscrew the screw.
- For solid cable, enter cable directly into the terminal block.
- For stranded cable use ferrules.
- Insert the cable connector into the terminal block.

Connect the following wires:

1. Earthing wire
 2. Neutral wire
 3. AC input wire single-phase
- Tighten the screws.

Step 3: Connect the AC Power Supply Cable

Connect the AC Input Cable - Three-Phase Power

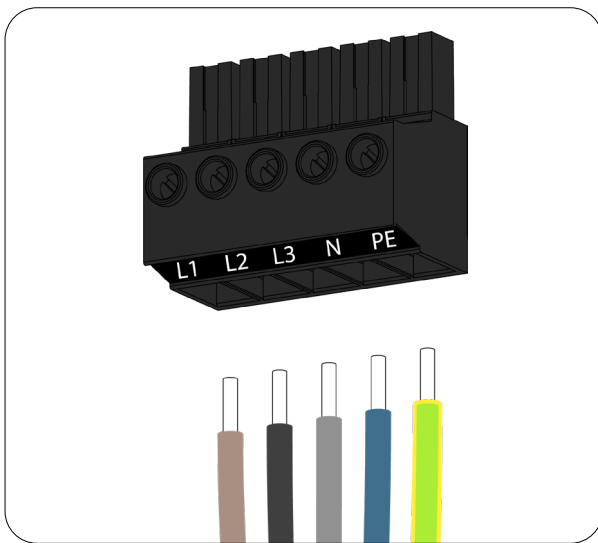

TN

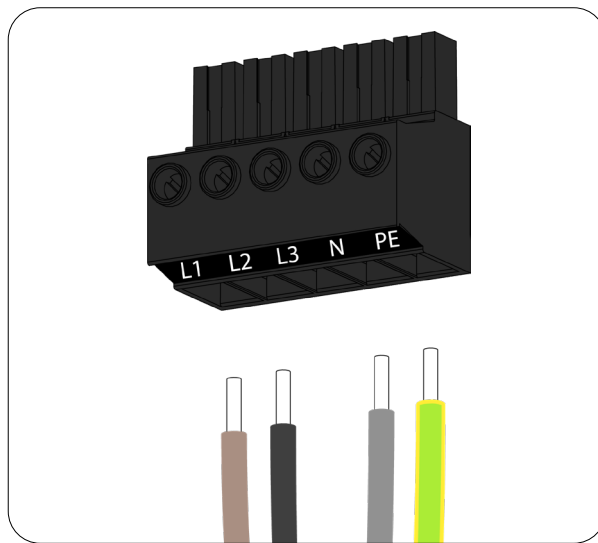

IT

- Unscrew the screw.
- For solid cable enter cable directly into the terminal block.
- For stranded cable use ferrules.
- Insert the cable connector into the terminal block.

Connect the following wires:

1. Earthing wire
2. Neutral wire (TN)
3. L1
4. L2
5. L3

- Tighten the screws.

Step 4: Install the Charge Controller

Step 4: Install the Charge Controller

*If the charger is going to be installed without the charge controller, then skip this step and put the blind in the cable plug hole, and push the front panel with slight force on top of the charger.

- Connect the terminal block to charge the controller's left-side socket.
- Connect the charging cable that comes pre-equipped with the terminal block to the right-side socket on the charge controller. If applicable connect the Ethernet cable(s) to the Ethernet socket(s).
- Ensure that all cables and connections are securely plugged in.
- Push the charge controller into the charger case. Listen for the click and make sure the controller is fixed properly.

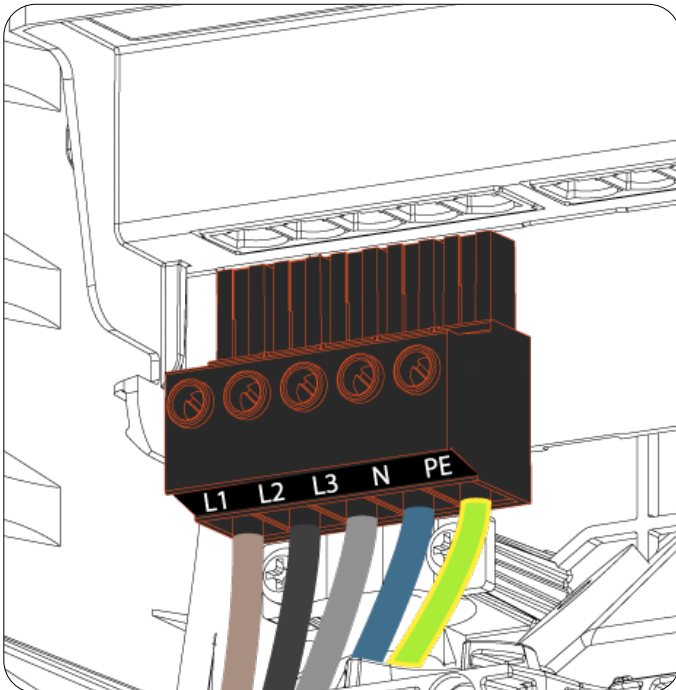

Power-in socket

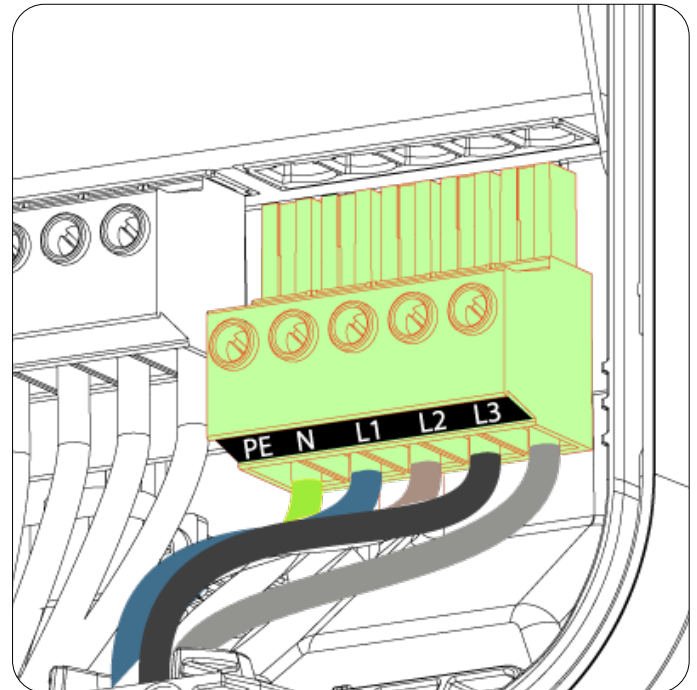

Charging cable

Step 5: Plug in the Ethernet Cable (Optional)

Step 5: Install the Ethernet Cable (Optional)

The Ethernet cable is used for a local area network. It transmits data between different devices. For example, if you want to connect the charger to the VOOO Load Management Controller (LMC) or with other chargers, you can install an Ethernet cable to speed up the data transmission process. This ensures reliable network connectivity and high-speed data transfer. Ethernet cables have RJ-45 connectors on both ends.

- Use the smaller holes on the charger case and smaller grommets for the Ethernet cable.
- If your charger is connected to the VOOO LMC or the VOOO LMC plus chargers, connect the Ethernet cable to sockets on the top of the charge controller.
- If the charger is only connected to the LMC, connect the cable to the left-side Ethernet socket.
- If the charger is connected to the LMC and other chargers then use the right-side side Ethernet socket to connect to the next charger in line.

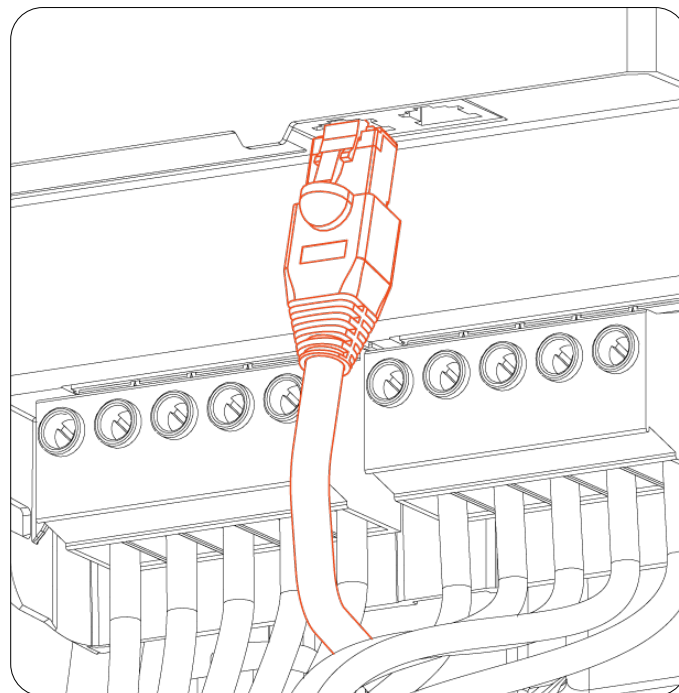

Ethernet cable

Step 6: Plug in the Charge Controller Lid

6.1 Plug in the small wire from the charger cable into the socket found under the charge controller lid PCB board.

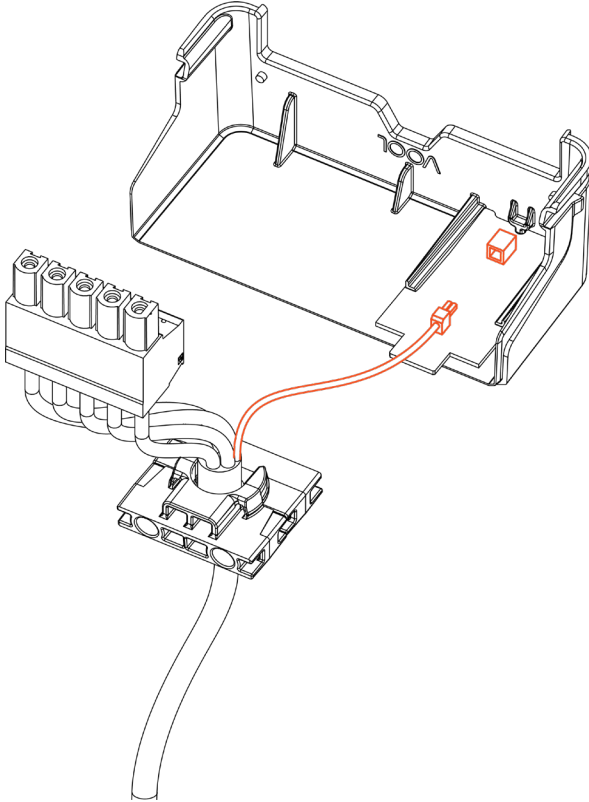

6.2 Follow the steps below to connect the charge controller lid.

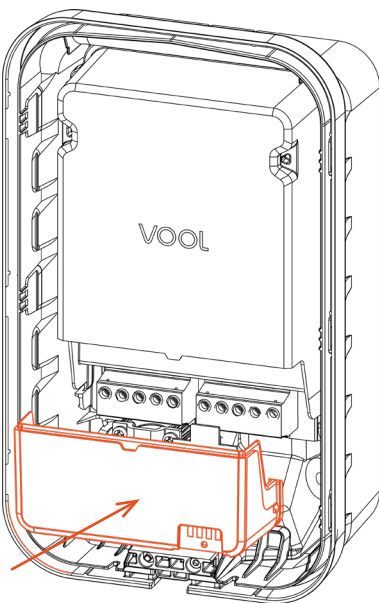

Step 1

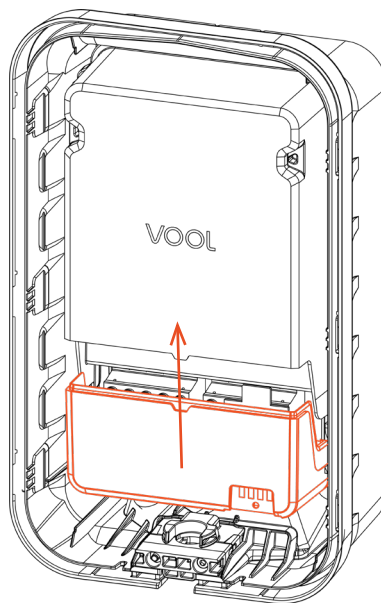

Step 2

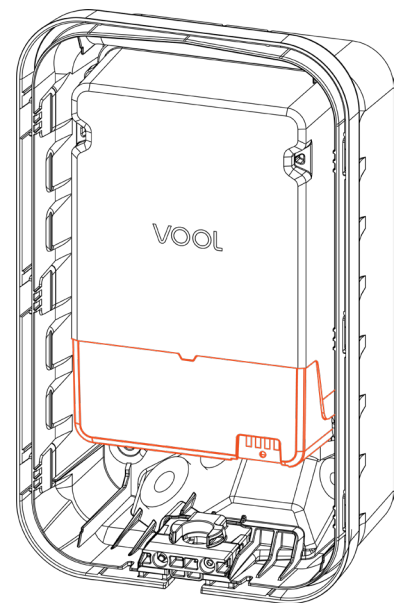

Step 3

Step 7: Snap on the Front Panel

Step 7: Snap on the Front Panel

The expansion board is located inside the cover for the charge controller and will be used to connect the front panel power and communication. Check that the front panel lights up in white. If any other color is displayed or there is no visible light at all, please refer to the troubleshooting section.

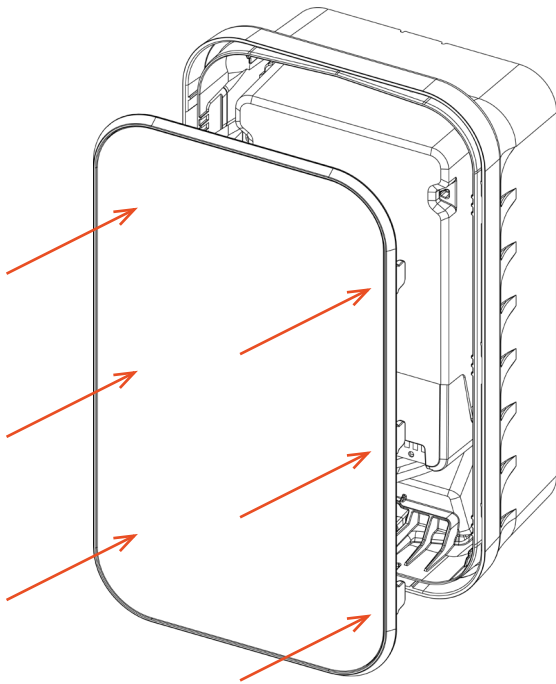

Step 1

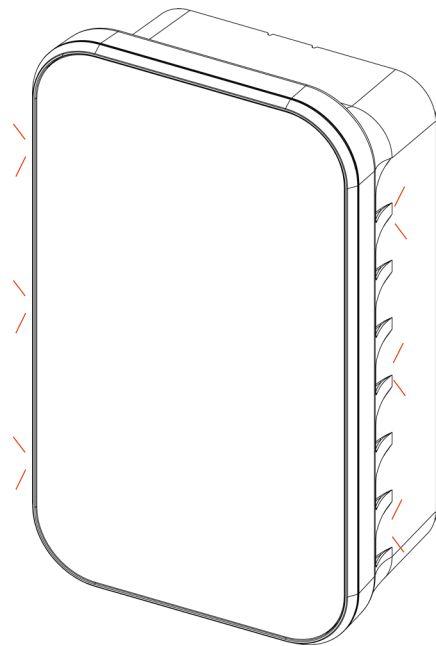

Step 2

Connect to the
VOOL Network

Add the Charger via the VOOB Portal

Navigate to app.vool.com on your web browser

- Double-check that the cabling is done correctly and switch on the power from the switchboard.
- Check that the VOOB logo on the charge controller lights up in green color.
- If the VOOB logo does not light up, it indicates that the power supply is either not connected or connected incorrectly. Please refer to the troubleshooting manual for further guidance
- If the light blinks red, it indicates something is incorrectly connected
- The charger can be connected to the internet via Ethernet, WiFi, or 4G. The charger will check the connections in that order.
- Connect to the charger via Bluetooth via the VOOB App.
- If the VOOB logo turns green, then the charger is connected to the internet and can be added to the VOOB Network.
- To set up a new charger add a new charge point.

Add a New Charge Point Charger via the VOOB App

- In the VOOB App, under My Profile, open the Installer Flow view. Choose a location where you would like to add the new charging point.
- Add the chosen device.
- If you don't have 4G connectivity set up WiFi connection in the VOOB App.

Connect via WiFi Hotspot

To set up a WiFi hotspot connection

- Make sure your device can create a WiFi hotspot and enable the hotspot on your device.
- Once the hotspot is enabled, you can customize the hotspot settings. Choose a security type (WPA2) and set a password for secure access.
- Connect the VOOB Charger with the hotspot. Your hotspot network should appear in the list of available networks.
- Enter the password that you created.
- Once connected, you should see an indication of a successful WiFi connection on the charger.

Adjust Charger Settings

Charger parameters, such as voltage and current are predetermined by the manufacturer. Adjust the charging settings in the VOOB Portal or the VOOB App under the Settings option. You can modify settings to make the desired changes. After adjusting the settings, save the changes and apply them to the charger. Monitor the charging process via the VOOB Portal or App to ensure that the edited settings are working as intended.

Troubleshooting

⚠ If you need to de-energize the charger turn off the power supply and wait at least 30 seconds before proceeding.

Error code	Issue	Troubleshooting
01	The charger received inaccurate information from the vehicle.	Switch off the charger from the main switch. Then switch it back on. If the error persists contact the manufacturer at support@vool.com .
02	The sensor of the residual current is not working.	Contact the manufacturer at support@vool.com .
03	There is an internal malfunction in the charger.	Contact the manufacturer at support@vool.com .
04	The residual current is discovered in the charging circuit.	Switch off the charger from the main switch. Then switch it back on. If the error persists contact the manufacturer at support@vool.com .
05	The charger has detected a malfunction in the vehicle.	Turn off the charger from the main switch, and turn it right back on. If the error persists contact customer service at support@vool.com . If possible, try to charge another vehicle.
06	The vehicle exceeded the allowed charging current.	Turn off the charger from the main switch, and turn it right back on. If the error persists contact customer service at support@vool.com . If possible, try to charge another vehicle.
07	The charger detected a short circuit in the cable.	The cable may be defective. Restart the charger from the main switch and if the error persists, try using another cable for charging.
08	The temperature is too high.	Allow the charger to cool down and try again. If the ambient temperature is too high, try to cool down the environment.

9	An error occurred while locking or unlocking the charging cable.	Make sure the charging cable is not too stretched or strained. Push the plug deeper into the socket and try again. If the error reoccurs then replace the charging cable with a new one.
10	A fault in the charging contactor applied the system protection device RCD	Turn on the RCD protection device. If the error persists, contact customer service.
11	There is no connection between the energy consumption meter and the charging station.	Contact the manufacturer at support@vool.com .

Technical Data

CHARGER SPECIFICATIONS

FEATURES

User identification	RFID, VOOL APP
Dynamic Load Management (DLM)	DLM ¹ and Dynamic Phase Management (DPM) ¹
DLM response time	Below 50ms ¹
Compatible EVSE protocols	OCPP 1.6, OCPP 2.0 ²
Energy metering	Integrated
Firmware update	OTA, USB, CAN

EXTERNAL INTERFACES

Internet connectivity	4G, Wi-Fi (IEEE 802.11 b/g/n), Ethernet 10/100
External energy meter	Modbus RTU(RS485)
Local device network	CAN

SAFETY

Residual current detection	Integrated type A and type B RCD
Compliance	LVD
Electrical protection	Protection CLASS I, overvoltage category III
Extra safety features	Relay contact diagnostics, self-test, thermal throttling

GENERAL SPECIFICATIONS

Dimensions (H x W x D)	335 x 198 x 112 mm
Weight	5.5 kg
Operating temperature	-30...+50 C ³
Enclosure environmental rating	Outdoor / IP55
Impact resistance	IK10
Standards	EMCD 2014/30/EU, IEC 61851-1:2017, IEC 61851-21-2:2018, IEC 62955:2018
Standard warranty	5 years
Network standards	TN, IT
Network voltage	230 VAC / 400 VAC (±10%)
Charging options	1 phase, 2 phase ⁴ , 3 phase
Rated power	22kW (32A)
EV connection	Type 2 tethered cable (6.5m)

¹ Connection with VOOL LMC is required

² Chargers installed with LMC

³ Forced ventilation available for hot environmental conditions

⁴ 2-Phase charging only available with compatible EV models; 3-phase grid connection required

Warranty Information

General Terms

The VOOl Charger Limited Warranty provides coverage for a period of 5 years (5 years for EU member states) from the date of purchase. The Limited Warranty covers the refund, repair, or necessary replacement of adapters that have manufacturing defects occurring during normal use.

The VOOl Charger Limited Warranty does not provide coverage for any damage or malfunction caused directly or indirectly by normal wear and tear, abuse, misuse, carelessness, accidents, or using the charger in a manner unsuitable for its intended purpose. The Limited Warranty does not provide coverage for improper maintenance, storage, or transport. This includes but is not limited to, situations where

- maintenance and warnings specified in the documentation are not followed.
- external factors, including but not limited, such as faulty electrical wiring, damaged junction boxes, circuit breakers, power outlets, environmental factors, or natural disasters such as fire, earthquake, water, lightning, etc.
- paint damage or any general appearance minor damages that may occur on the surface such as scratches, scrapes, small marks or notches, bumps, or fractures.
- the VOOl is not contacted immediately after discovering a defect that is covered by the warranty.
- non-certified parts or accessories or any other modification is made by an unauthorized person or facility.
- there is improper repair or maintenance, without non-genuine accessories or parts.

While it is not mandatory for you to have all maintenance, service, or repairs done at the VOOB service center, the Limited Warranty may not provide coverage when there are inadequate maintenance, service, or repairs. For this reason, it is advised you have all maintenance services and repairs performed in an authorized repair facility.

Apart from the rights provided under the VOOB Charger Limited Warranty, you may be entitled to additional legal rights based on the laws in your local region or country.

Limits of Liability

This limited warranty is only for the VOOB Charger. Any other warranties or conditions that may arise under relevant local laws, federal statutes, or otherwise, in law, including but not limited to implied warranties and conditions of merchantability or merchantable quality, durability, or those arising by a course of dealing or usage trade, are either disclaimed to the maximum extent permitted by your local law or limited in duration to the term of this VOOB Charger Limited Warranty.

To the maximum extent permitted by your local law, necessary repairs and/or replacements will be carried out using new remanufactured components. By your local law, the liability of the VOOB Charger Limited warranty is limited to a reasonable cost of repair or replacement. This cost will not exceed the manufacturer's suggested retail price. If the replacement is necessary, it may be fulfilled with non-original manufacturer's parts of similar quality.

If the costs of repairing or replacing the VOOB Charger exceed its fair market value at the time when the defect was discovered, VOOB will not be responsible for covering such costs. Furthermore, the total benefits you receive under this VOOB Charger Limited Warranty cannot exceed the price you paid for the VOOB Charger.

VOOB does not allow create any additional responsibilities or liabilities on behalf of the company. VOOB company reserves the right to decide, whether to repair or replace a component and whether to use new, reconditioned, or remanufactured parts.

To the extent allowed by local law, VOOB declares that it takes no responsibility for any indirect, incidental, special, or consequential damages arising from or relating to the VOOB charger or adapter. Including, but not limited to transportation, loss of the charger, reduction of the vehicle value, loss of time, income, personal or commercial property, inconvenience or annoyance or emotional stress or harm, expenses that are made for towing, bus fares, vehicle rental, service call charges, gasoline expenses, lodging expenses and incidental expenses such as telephone calls, emails, etc.

Regardless of the nature of your claim, whether it is based on contract, tort, breach of warranty or conditions, misrepresentation, or any other law, these limitations and exclusions will still apply. This includes the situations where damages were reasonably foreseeable.

Laws and Dispute Resolution

In compliance with local laws, VOOB requests that you notify them in written form of any manufacturing defects within a reasonable timeframe and during the coverage period specified in the VOOB Charger Limited Warranty. This will allow us to perform any necessary repairs. If you have any disputes that require resolution, please send a written notification to:

support@vool.com or
Telliskivi 51b
10611, Tallinn
Estonia

For more information, support,
or inquiries, please reach out to us at

info@vool.com

VOOL