

Operating instruction **Video intercom system**

Outdoor unit single user manual



APP unlocking



NFC



IC card swiping



IP65



Infrared night vision

120°

Wide-angle 120°

Please read this Instructions carefully before use to ensure the correct use of this product

Content

| | |
|--------------------------------------------------------------|---|
| I. Product structure | 1 |
| II. Product parameters | 1 |
| III. Operating instructions | 2 |
| IV. System information | 2 |
| V. Wiring diagram | 3 |
| VI. Operating instructions on Wi-Fi network connection | 3 |
| VII. APP instructions | 8 |
| VIII. Installation instructions | 9 |
| IX. Operating instructions for nameplate placement | 9 |



Matters needing attention

a. Test before installation

Open the package, check whether the accessories are complete, use the original test cable for the outdoor unit and indoor unit, whether it work normally, and then install.

Note: The wiring must be strictly in accordance with the connection diagram of the manual, otherwise the function not be used normally, or even damage the equipment; please refer to the purchased access control power supply manual for the use of the access control power supply, which is not included in the set.

b. Maintenance

1. Don't use it with any product not produced by our company;
2. Users shall follow the user manual strictly to install and test the product. Please call our company for technical support if you have any question.

VIII. Installation instructions

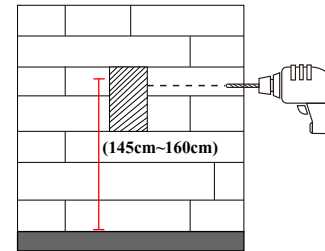

1. Determine the location and height for installing ; the reference height is 145-160cm from the Camera center to ground;
2. It's required to avoid installing the outdoor unit at any place with strong direct sunlight;
3. Locate the position and groove the wall with a percussion drill, with a depth of about 3 cm;
4. Embed the required power cord.

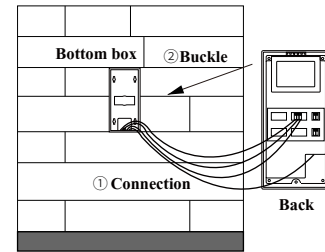

1. Correctly connect power cable to wiring terminals on the back of outdoor unit ;
2. Buckle outdoor unit into the bottom box that has been fixed on the wall.

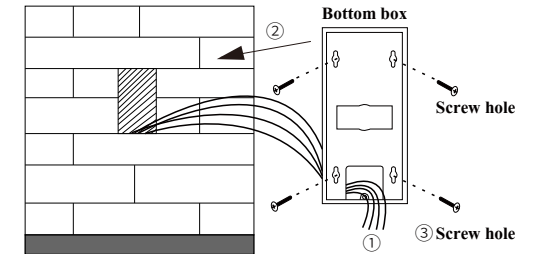

1. Route the power cable through the built-in bottom box of outdoor unit;
2. Arrange and finish power cord and fix the bottom box on the wall slot position;
3. Attach the box to the wall with expansion screws.

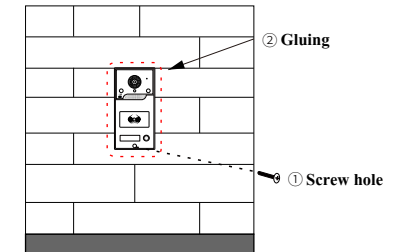

1. Fix the outdoor unit with screws
2. Seal the periphery of outdoor unit with sealant to ensure waterproof edges;
3. The installation is completed.

IX. Operating instructions for nameplate placement

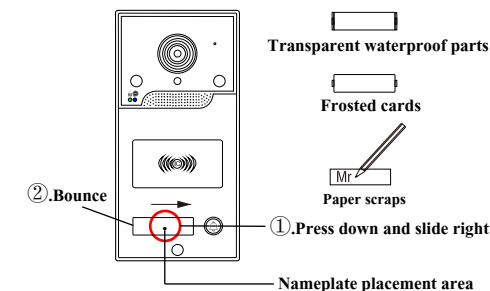

- ①. You can fill in floor / name plate and other information as you like.
- ②. Press down the middle area of the transparent part and slide right;
- ③. The transparent piece bounces, and remove the built-in transparent card and paper;
- ④. Fill in the information and put it back into the card slot to complete the operation.

VII.APP instructions

A)Introduction of functions on the APP interface

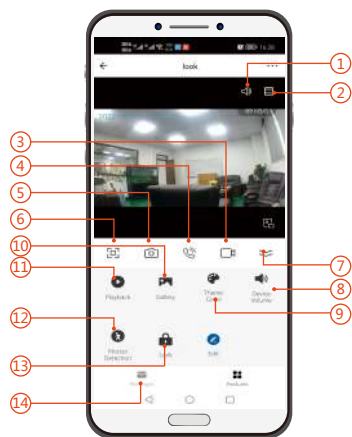

- ①. Mute mode
- ②. Magnification display
- ③. Video recording
- ④. Microphone
- ⑤. Photograph
- ⑥. Full screen display
- ⑦. Hidden menu
- ⑧. Intercom volume
- ⑨. Set theme color
- ⑩. Storage location of photo and video recordings
- ⑪. Storage location of call and motion detection recordings
- ⑫. Open or close motion detection
- ⑬. Remote unlocking button
- ⑭. Call message list



Note: One account for one device only. Please delete the bound device before connected to new account; otherwise, the new device may fail to be added.

B).Add members

a). Take out the mobile phone bound with the device, enter the APP, click "My" in the lower right corner → select "Family management" → select the created family group → "Add members" → invite members to join through "WeChat", and click on the members you want to invite to "Share" the invitation code.

b). The invited members shall also download the "TuYa smart" APP and log in (without binding the device) → click "My" in the lower right corner → select "Family management" → join a family → open "WeChat" to view the invitation code → return to the APP and enter the invitation code.

c). On the bound mobile phone, click "Family management" → select family → view the newly added family members → the number marked with "Family owner" is the main number → you can click family members for editing → there are functions of "Family role" / "Remove from family", etc.

d). Newly added members shall click the "Home page" → click "My home" on the upper left corner to select "Home name" to keep the home on top.

e). The dominated administrator of a family can share and add unlimited mobile phone users, and remotely monitor and view the outdoor conditions with 5 mobile phones at the same time.

B)How to open motion detection

Click the motion detection icon to open it. Any moving object will automatically open its recording function, and click the icon again to close the motion detection.

C)Playback function

Only the recordings of calls and motion detection can be played back.

I.Product structure

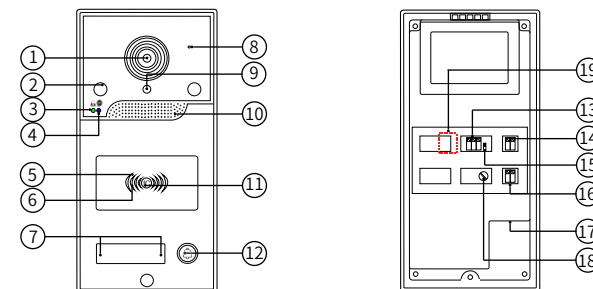

Figure 1

| | |
|----|------------------------------------------------------------------------|
| 1 | HD camera |
| 2 | Infrared night vision light |
| 3 | Green indicator representing unlocking status |
| 4 | Blue indicator representing standby status |
| 5 | Green indicator representing swiping/adding user card status |
| 6 | Red Indicator representing deleting user card/unregistered card Status |
| 7 | White indicator representing door number |
| 8 | Microphone |
| 9 | Night vision sensor |
| 10 | Speaker |

| | |
|----|-------------------------------------------------------------------------|
| 11 | White indicator light representing standby status |
| 12 | Call button |
| 13 | Pressing type conductive signal port |
| 14 | Pressing type electric lock port |
| 15 | Reset the management card toggle switch |
| 16 | Pressing type DC15V 1.2A power portort |
| 17 | Network cable port |
| 18 | Unlocking delay regulator |
| 19 | Built-in TF card,supporting up to 128GB (Rear cover to be disassemble) |

II. Product parameters

| | |
|--------------------------|------------------------------------------------------------------------|
| Camera | 2 megapixel |
| Power supply | Outdoor unit power supply(15V 1.2A)/national standard POE power supply |
| Power | Standby: ≤ 3W |
| IC card frequency | 13.56MHz |
| Camera angle | 120 ° Wide-angle |
| Night vision sensitivity | 0.001 Lux |
| Night vision distance | 10M |
| Night vision function | Infrared night vision |
| Working temperature | -30 ℃ ~60 ℃ |
| Waterproof class | IP65 |
| Installation method | Embedded installation |
| Integral unlocking time | 1-20S |
| Material | Aluminum alloy+ABS engineering plastic |
| Unlocking type | Mobile phone APP remote unlocking/IC card swiping/ NFC |
| Number of IC cards | 2000 PCS |
| Card reading time | 1s |
| Size | 173*85*41mm |

III. Operating instructions

A. Restore factory settings

After connecting the device correctly, Power on for 10 seconds → The blue indicator light flashes slowly in standby status (Figure 1.4) → Press and hold the call button for 10 seconds until the blue indicator light goes out → Release the button → The blue indicator light enters slow flashing again → The factory settings are restored successfully.

B. Learn to create management cards

⚠ Note: Before the following steps, please read the operation steps carefully. If there is no continuous operation action within 10 seconds during the operation process, the system will automatically exit the operation interface after the system "Didi" twice. If the operation fails, it needs to be re operated.

a) Registration management card

First, when the outdoor unit is not connected, Down-toggle learning management card switch (Figure 1.15) → Then connect the outdoor unit (buzzer "Drip" once) → The green indicator light flashes (Figure 1.5), swipe the first additional card (green card) (buzzer "Drip" once) → Swipe the second deleted card (red card) (buzzer "drip" once) → The outdoor unit power off → Dial the learning management card switch up and reset → The management card is completed.

b) Add user card

Swipe the additional card (green card) (buzzer "Drip" once, and the green status indicator in the IC card swiping area is long on) → Swipe the blank card again (buzzer "Drip" once, and if you want to add multiple user cards at the same time, you can continuously swipe the blank card) → Swipe the additional card (green card) again to confirm (buzzer "Drip" twice, and the green light goes off to complete the addition)

c) Delete User Card

Swipe the deleted card (red card) (buzzer "Drip" once, and the red status indicator in the IC card swiping area is long on) → Swipe the card to be deleted again (buzzer "Drip" once) → Swipe the deleted card (red card) again to confirm (buzzer "Drip" twice, and the red light goes off to complete the deletion)

d) Delete all user cards

Swipe the deleted card (red card) (the buzzer "Drip" once, and the red status indicator in the IC card swiping area is long on) → Swipe the additional card (green card) again, and the buzzer "Drip" once. Swipe the deleted card (red card) again to confirm (the buzzer "Drip" once, and the red light flashes quickly) → The buzzer "Drip" continuously for 7 times, then the user card is all cleared and deleted.

IV. System information

A. Set the unlocking delay adjuster

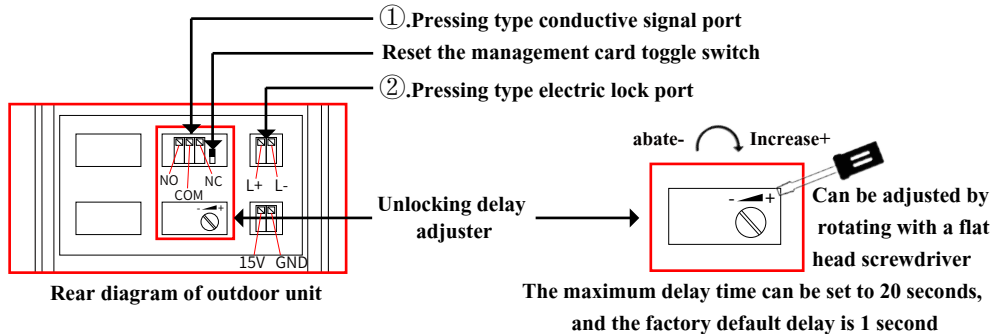

⚠ Note: If the electric lock is connected, it doesn't need to adjust the delay time

E).Method 3(Router Wired Network Connection)

Connect network cable to machine and power on → Connect network cable to router → Connect phone and router in the same WIFI

01 Click ① "Add device"

02 Click ① "Camera & Lock"
② Select "Smart camera (Wi-Fi)"

03 Click ① in the upper right corner and select "Wired Network Connection"

04 ① Tick the option,
② Click "Next"

05 The mobile phone starts to connect Wi-Fi

06 ① click "Complete" in the upper right corner after successful network pairing

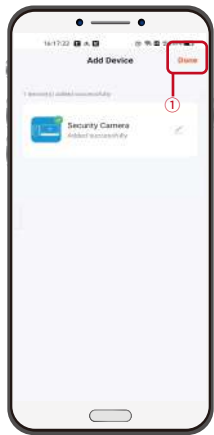

07

①click “Complete” in the upper right corner after successful network pairing

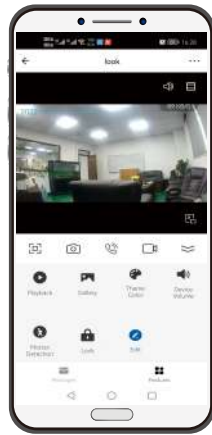

08

Now, network connection is complete



D).Method 2(POE Switch Wired Network Connection)

Power on POE switch → Connect network cable to outdoor unit → Connect network cable to switch → Connect phone and router in the same WIFI(as shown in Figure 3)

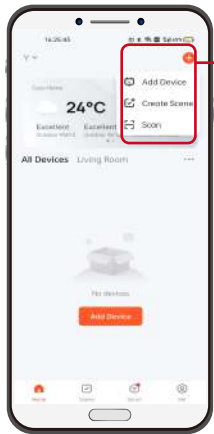

01

Click ① in the upper right corner "+" and select "Add Device"



02

Activate the phone Bluetooth, ① System will automatically search for the device or the searched device will pop up



03

①When the device is found, click “Add”

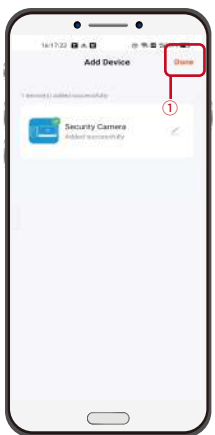

04

①click “Complete” in the upper right corner after successful network pairing



V.Wiring diagram

A).Wiring Diagram of Entry Electronic control lock

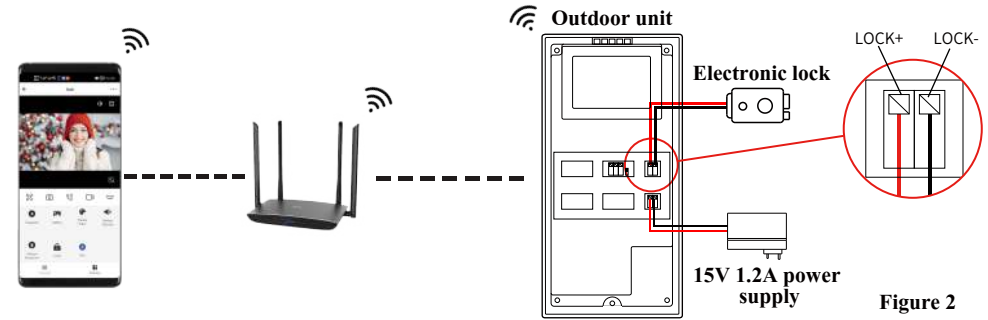

Figure 2

B).Wiring diagram of door access control system

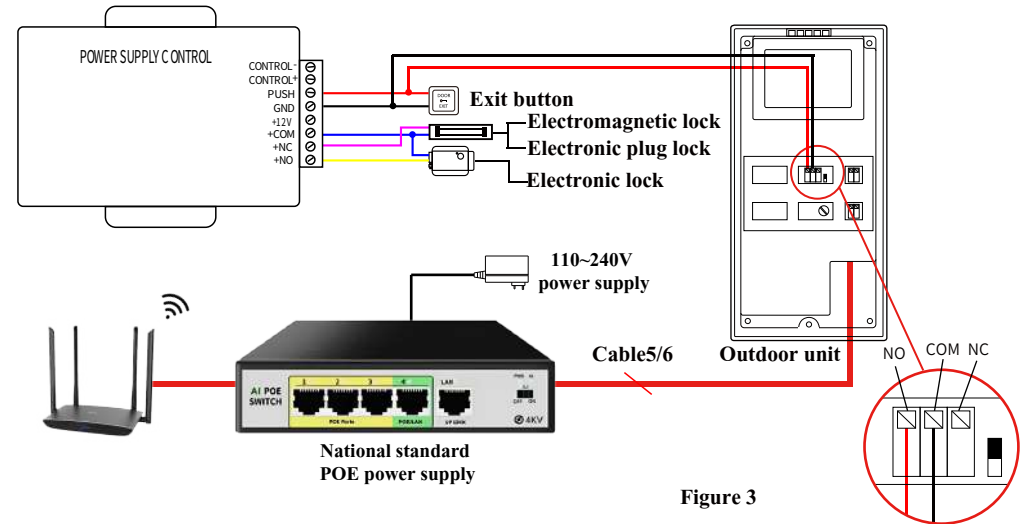

Figure 3



Note: For the operation of access control power supply, please refer to the operation manual for the access control power supply purchased by yourself.

VI.Operating instructions on Wi-Fi network connection

A).Download TUYA APP and complete the registration.



Apple / Android
Scan QR Card Download APP

B).Create a Family Group

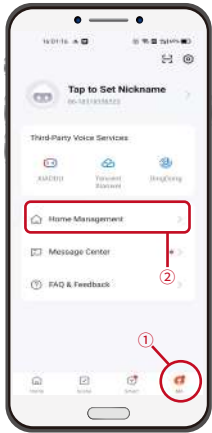

01

Open app
Click ① "Me"
Select ②
"Home Management"



02

Click ① "Create a home"

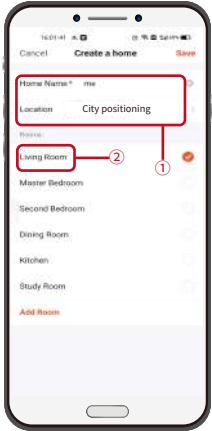

03

Create ① "Home name"
and select "City positioning"
② Select a room location

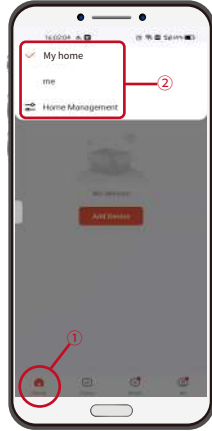

04

Click ① "Home page"
② Click the top left
corner Select the
"Family name" you just
created in "My home"

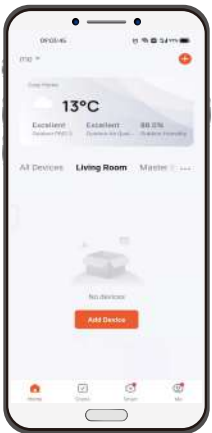

05

Now, the Family Group is
created

C).Method 1(Wireless Network Connection)

Power on the machine (as shown in Figure 2) → Standby indicator flashes (as shown in Figure 1.4), and Startup tone is heard → Open TUYA APP → Follow the following steps.

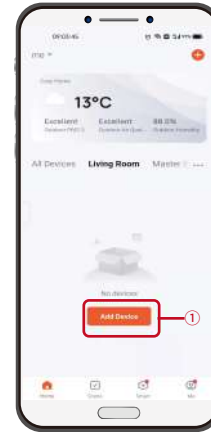

01

Click ① "Add device"



02

Click ① "Camera & Lock"
② Select "Smart camera (Wi-Fi)"

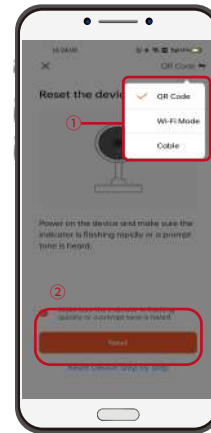

03

Click ① in the upper right
corner to select "QR Code
for Network Connection",
② Tick and Click "Next".



04

Select 2.4GHz Wi-Fi
Network Enter
① "Current WiFi name
and password",
Click ② "Next"



05

Make the camera of the
outdoor unit directly face
to the pop-up QR code,
with a scanning distance
of 15-20cm, ①click
"Hear the prompt tone"
after you hear it



06

The mobile phone starts to
connect Wi-Fi

